

SR130 Switched Reluctance Motor

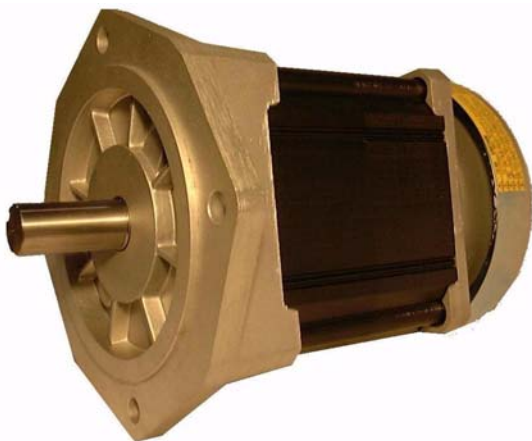

- **Four Phase, Fault Tolerant Construction**
- **Three Standard Sizes available**
- **Four Standard Operating Voltages**
- **Compatible Drive Systems are available**
- **3.1 HP peak and 1.8 HP continuous**

▪ **FEATURES**

- **SR design:** The inherent benefits and simplicity of Switched Reluctance Motors (SRM) allow for high speed and high torque operation at high efficiency. Switched Reluctance Motors operate without magnets.
- **Multiple stack lengths:** Three stack lengths are part of the standard product line. These choices provide a range of motor performance from one flange size, allowing for increased motor torque with the same equipment.
- **Motor Drive Availability:** A range of standard drives as well a custom drive design and manufacturing capability allow for an optimally matched system. Please contact us for more information.
- **High torque and efficiency:** The SR motor allows for simplification of the system design and improvement of total system efficiency.
- **Flexibility in motor winding selection:** A range of standard windings has been selected for common operating voltages. Production motors can be tailored for specification application profiles to optimize the performance and efficiency.
- **Regenerative capability:** The SR motor technology is well suited for both motor and power generating applications. For electric vehicle applications, four quadrant regenerative braking allows recharging of the batteries during braking and dramatically improves the range.

SPECIFICATIONS

Model No.	HP Peak	HP Cont.	Peak Torque lb-in (Nm)	Max speed rpm	Shaft OD inch/mm	Weight lbs. (kg)
SR130S	1.1	0.6	12.0 (1.3)	15,000	0.55 (14)	9.7 (4.4)
SR130M	2.0	1.2	21.6 (2.4)	15,000	0.55 (14)	12.1 (5.5)
SR130L	3.1	1.8	32.4 (3.7)	15,000	0.55 (14)	15.0 (6.8)

All data taken at a 6,000 RPM base speed. The SR130 is a Switched Reluctance motor that is well suited for traction applications. The high starting torque and efficiency makes it well suited for light vehicle and other demanding application. The motor uses a 8/6 topology in a four-phase configuration.

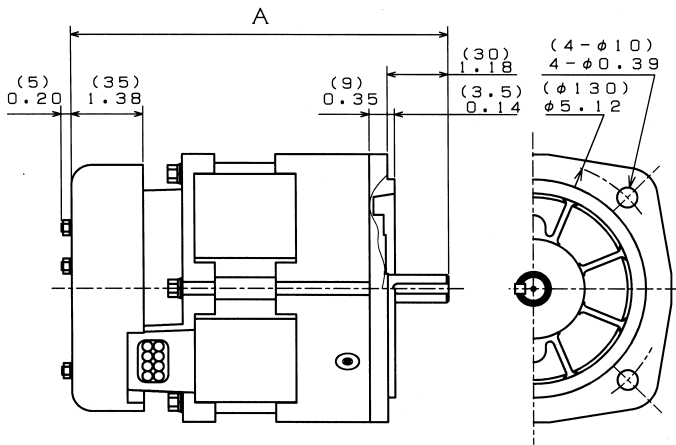

	A
RA130135	6.50 (165)
RA130155	7.28 (185)
RA130175	8.07 (205)

1999/4/28 DENSE I

Model Overall motor length w/ shaft

SR130S	6.50 in (130mm)
SR130M	7.28 in (185mm)
SR130L	8.07 in (205mm)

Other dimensions:

Flange bolt holes: 0.39 in (10 mm), 4 places

Flange size: 5.1 in (130 mm)
flange diameter to bolt centers

GENERAL SPECIFICATIONS

Peak Efficiency: 94.6%

Max. winding temp: 180°C

Connection: 8 winding leads
6 sensor wires

Standard voltages: 24VDC, 48VDC, 115VAC
Custom windings available
upon request

Rocky Mountain Technologies Inc.

11850 S. Hwy 191, Moab Business Park A-8
Moab, UT 84532

Tel: (801) 870-9900 or (435) 259-4000

Fax: : (801) 870-9901

e-mail: info@RockyMountainTechnologies.com

web: www.RockyMountainTechnologies.com

Specification subject to change without notice.